

# Indoor PH Series with Handle

## Electromagnetic Lock Installation Instructions

### A Specifications

Model	PH-500	PH-750	PH-760
Exit Button	✓	✓	—
Operating Voltage	12/24VDC		
Current Draw	500mA/12VDC 250mA/24VDC		
Operating Temperature	32° to +120.2°F (0° to +49°C)		
Bond Sensor Output	1A/24VDC		
Door Status Sensor	0.2A/12VDC		
Holding Force	600 lbs	600 x2 lbs	
Lock Surface Temperature	≤ Current temperature ± 20°C		
Special Finishes for magnet and armature plate	Zinc plated		

\*MTD : Bond sensor & Bi-color status LED indicator & Relock time delay

\*DS : Door status sensor 【Optional】

### B Connecting Diagram

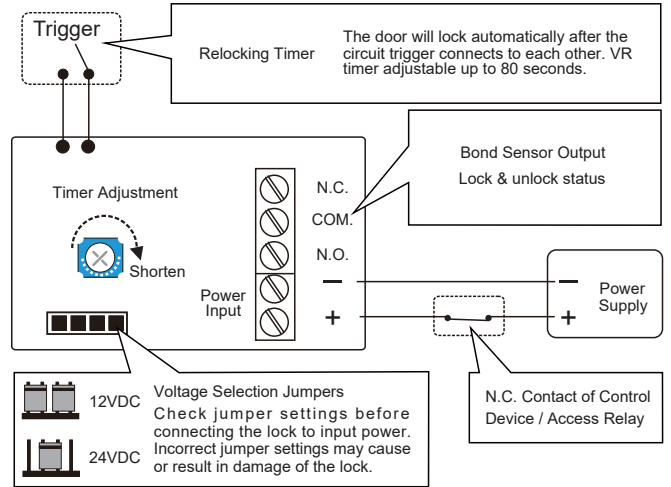

### C Dimension & Accessories

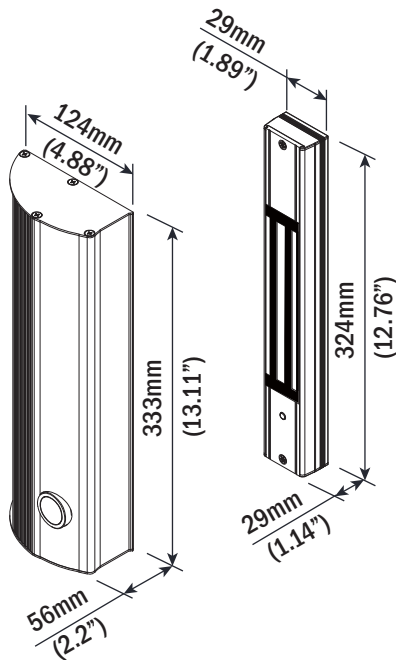

Model : PH-500MTD

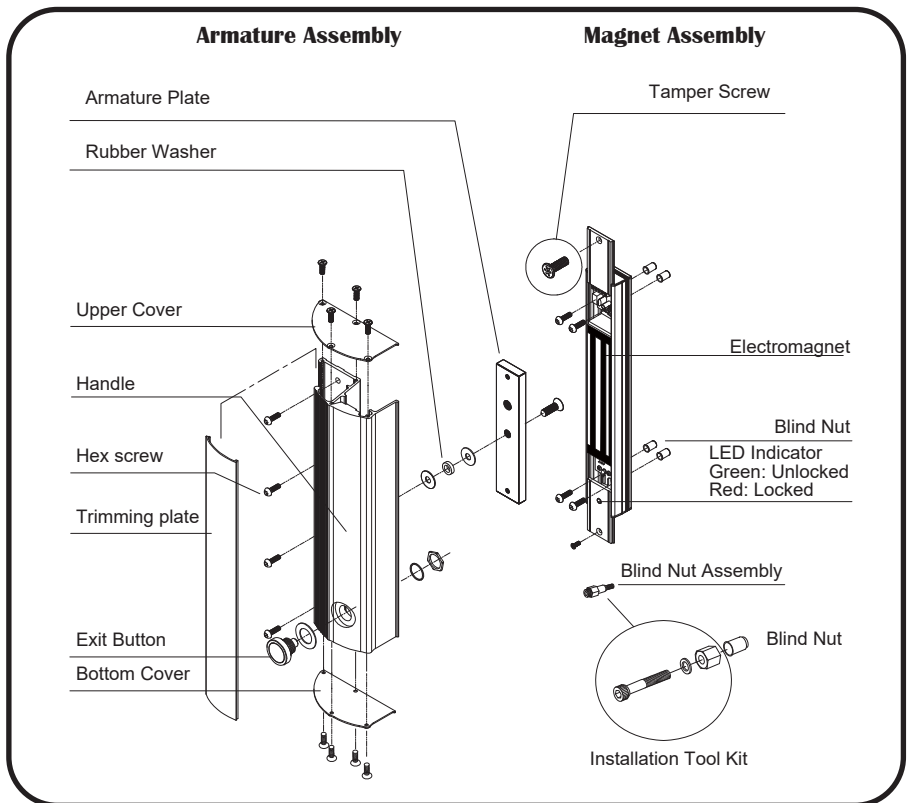

**Note:** If the armature plate is not aligned to the magnet or the reed within the magnet assembly does not sense the small magnet in the handle, remove the indicated washer to ensure normal operation.

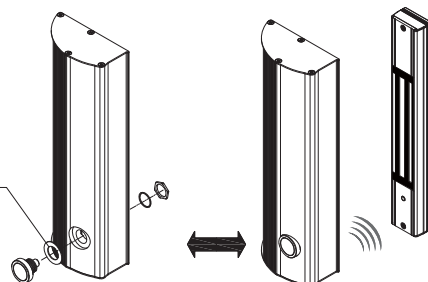

**Dimension & Accessories**

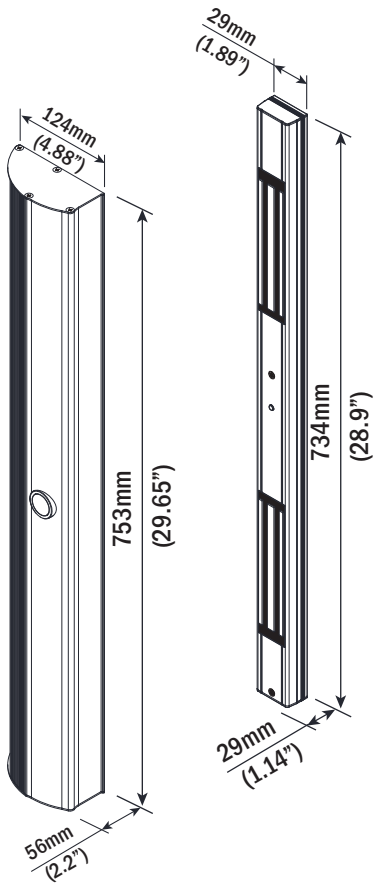

**Model : PH-750MTD**

\*DS : Door status sensor 【Optional】

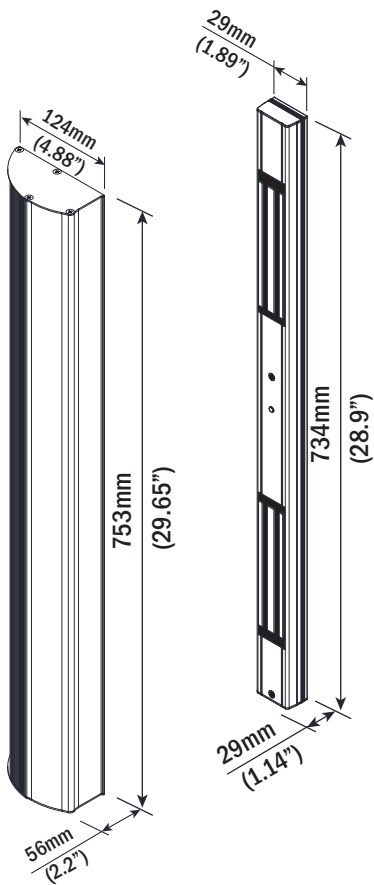
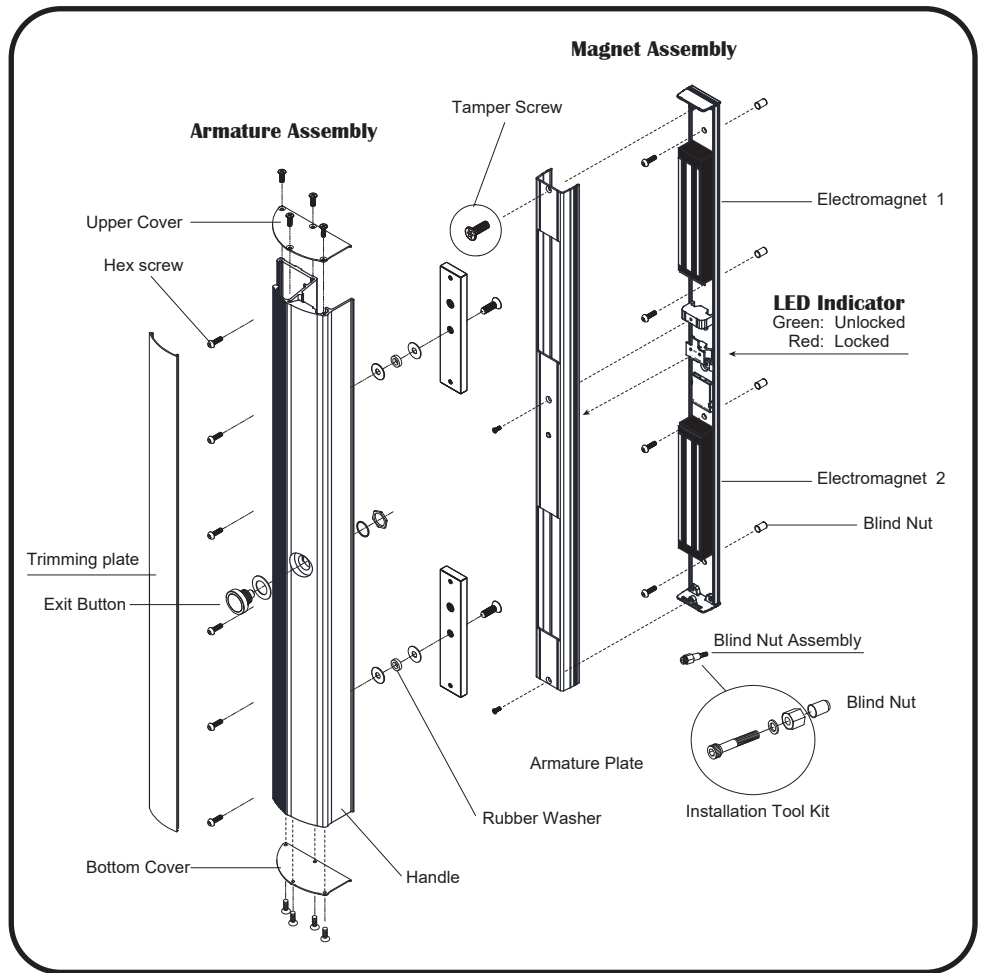

**Model : PH-760MTD**

\*DS : Door status sensor 【Optional】

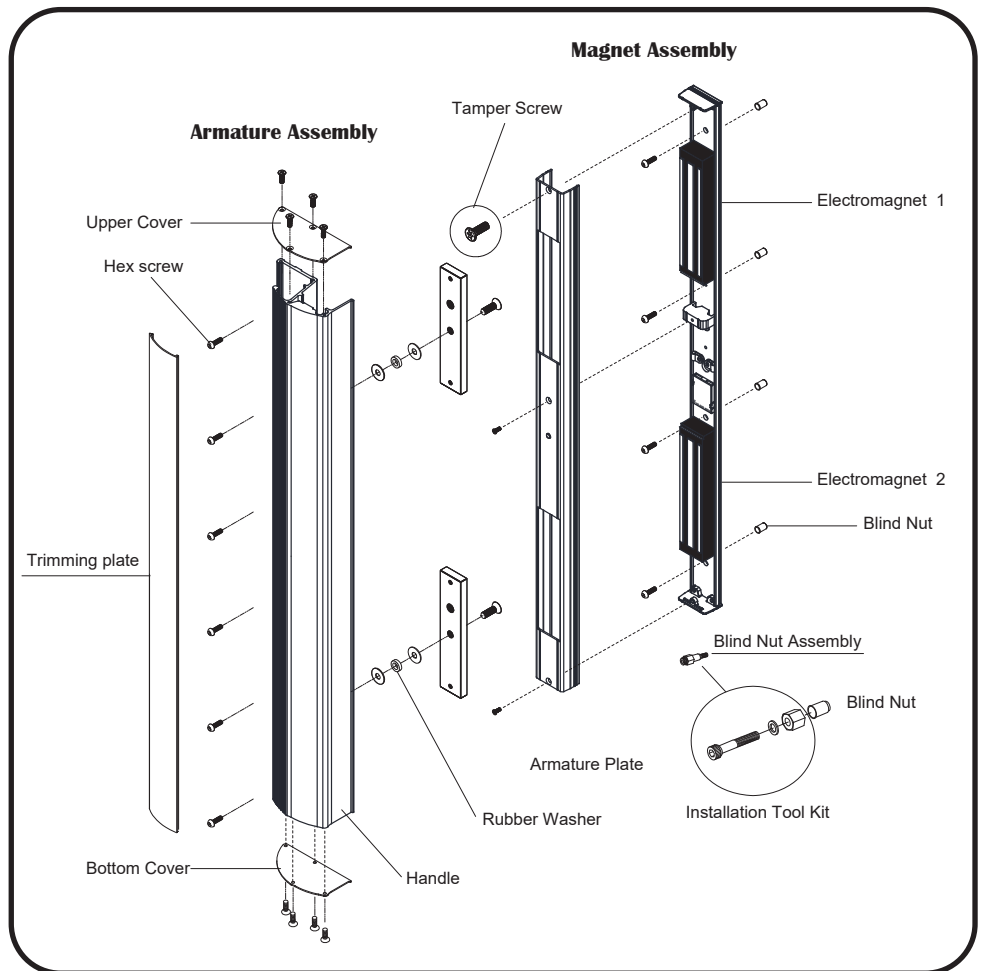

## D Installation Diagram & Template

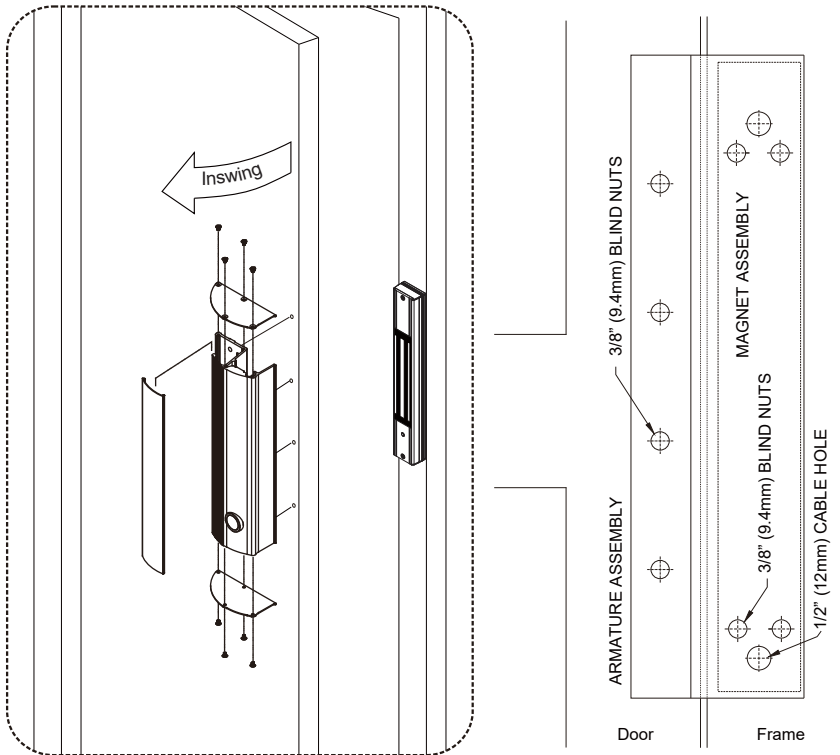

### Installation Instructions:

- 1 Close the door and make sure the door and door frame are at the same level of height. Add additional plate spacers if needed.
- 2 Place the template in the proper position on the door and frame.
- 3 Drill holes for cable access and blind nuts according to the template.
- 4 Install blind nuts and secure the magnet assembly.
- 5 Wire the magnet assembly.
- 6 Secure the armature plate assembly. After applying power, close the door and test the holding force. Add rubber washers if there is still a gap between the armature plate and magnet.

### Blind Nut Installation

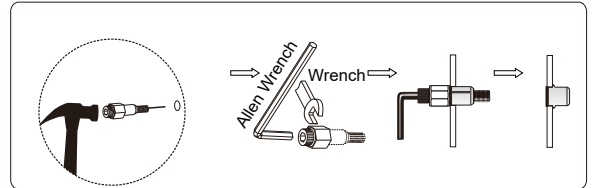

Drill a 3/8" (9.4mm) hole and hammer the blind nut assembly into the hole.

Use a wrench or vice-grip to tightly hold the nut. Then use the Allen wrench to slowly tighten the screw until it does not turn any further.

This compresses the blind nut so that it remains permanently fixed in the hole. Remove the installation tool from the blind nut.

## E Important Notes

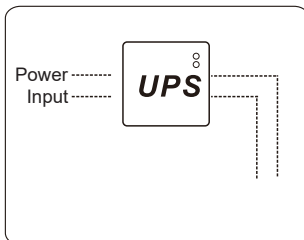

The electromagnetic lock is fail-safe and will require a power supply unit equipped with battery back up for fear that power failure may increase security risks.

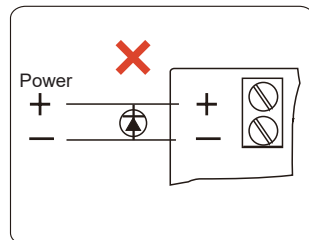

Do not install a diode or MOV in parallel with any magnetic lock. A diode will cause a delay when releasing the door.

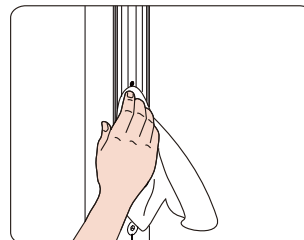

Apply a light coat of a silicon lubricant to prevent the maglock from rusting. Wipe off the excess.

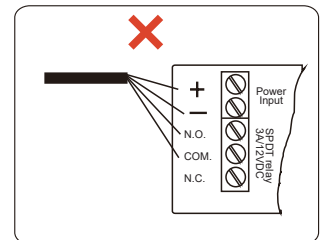

Do not strand power wires and signal wires in the same cable or conduit.

## F Trouble Shooting

Problem	Possible Cause	Solution
Door does not lock	No power	Make sure the wires are securely tightened to the correct terminal block
		Check that the power supply unit is connected and operating properly
		Make sure the lock switch is wired correctly
Reduced holding force	Poor contact between electromagnet and armature plate	Make sure the surface of the armature plate is in good shape
		Make sure the rubber washer is inserted behind the armature plate
		Make sure the contact surfaces of the electromagnet and armature plate are clean and free from dust
	Low voltage or incorrect voltage setting	Check the setting of power input volume
Sensor output is not functioning	A secondary diode was installed across the electromagnet	Remove any diode installed across the magnet for "spike" suppression. (The magnet is fitted with a metal oxide varistor to prevent back EMF)
	Misalignment between the armature plate and its magnet	Check the faces of armature plate and the maglock are aligned face-to-face