



Certifications

EN 62368-1:2014 + A11:2017
 EN 55032 Class B
 EN 55032 Class B (2015+A11:2020)
 IEC 61000-3-2 Ed.5.1 (2018+AMD1:2020),
 IEC 61000-3-3 Ed.3.1 (2013+AMD1:2017)
 EN 55035 (2017+A11: 2020)
 (IEC 61000-4-2 Ed.2.0 (2008)/-3 Ed.4.0 (2020)/
 -4 Ed.3.0 (2012)/-5 Ed.3.1 (2014+AMD1:2017)/
 -6 Ed.4.0 (2013)/-8 Ed.2.0 (2009)/-11 Ed.3.0 (2020))

Dimensions

Unit:mm

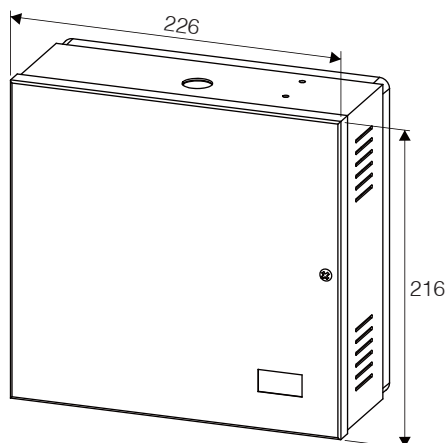

Power Supply PSC-122B

High Efficiency Switching Power Supply

PSC-122B is a high efficiency switching power supply with two independent outputs each with a maximum of 1A current. It is designed with a mounting bracket ABP-100 (two colours to choose from) for easy installation.

PSC-122B is ideal for use with a wide range of access control devices including electrified locks, magnetic locks, electric strikes and keypad readers. The PSC-122B also features battery charging capability and power/ battery status LEDs. Enclosed in a metal box, the power supply is securely stored with space also available for a rechargeable battery.

Standard Features

- Two independent power outputs for ease of connecting with electric locks and other devices.
- Distance between the power supply and output devices (e.g. electric locks) can be up to 50 meters.
- Electronically protected output 1 and 2 against shorting and overloading.
- Battery protection: electronically protected against battery reversal, shorting, or overloading.
- Power light: Red LED when input power is connected and off when power is off.
- DC light: Green indicates DC power output (or battery charging) is normal. Off or flashing when there is an issue.
- Battery light: Yellow LED when battery voltage is normal. Off when battery is discharging and voltage is below 10 VDC.
- ABP-100 mounting bracket is included with two colours to choose from

Specifications

- Input Voltage: AC100~240V, 0.6A 50/60Hz
- Output Voltage (each): 12.8 VDC
- Current Draw (each): 1 Amps Max
- Total Current Draw: 1.7 Amps Max
- Battery Charging Current
0.3 Amps Max (Maximum charge current to the 12VDC battery is approx. 0.28A)
- LED Indicator
Power Light (Red)
DC Light (Green)
BATT Light (Yellow)
- Weight: 70.55 oz (2000g)
- Dimensions: 8 1/4" x 8 11/16" x 3 1/8"
210 x 220 x 80mm (L*W*H)

Wiring Diagram

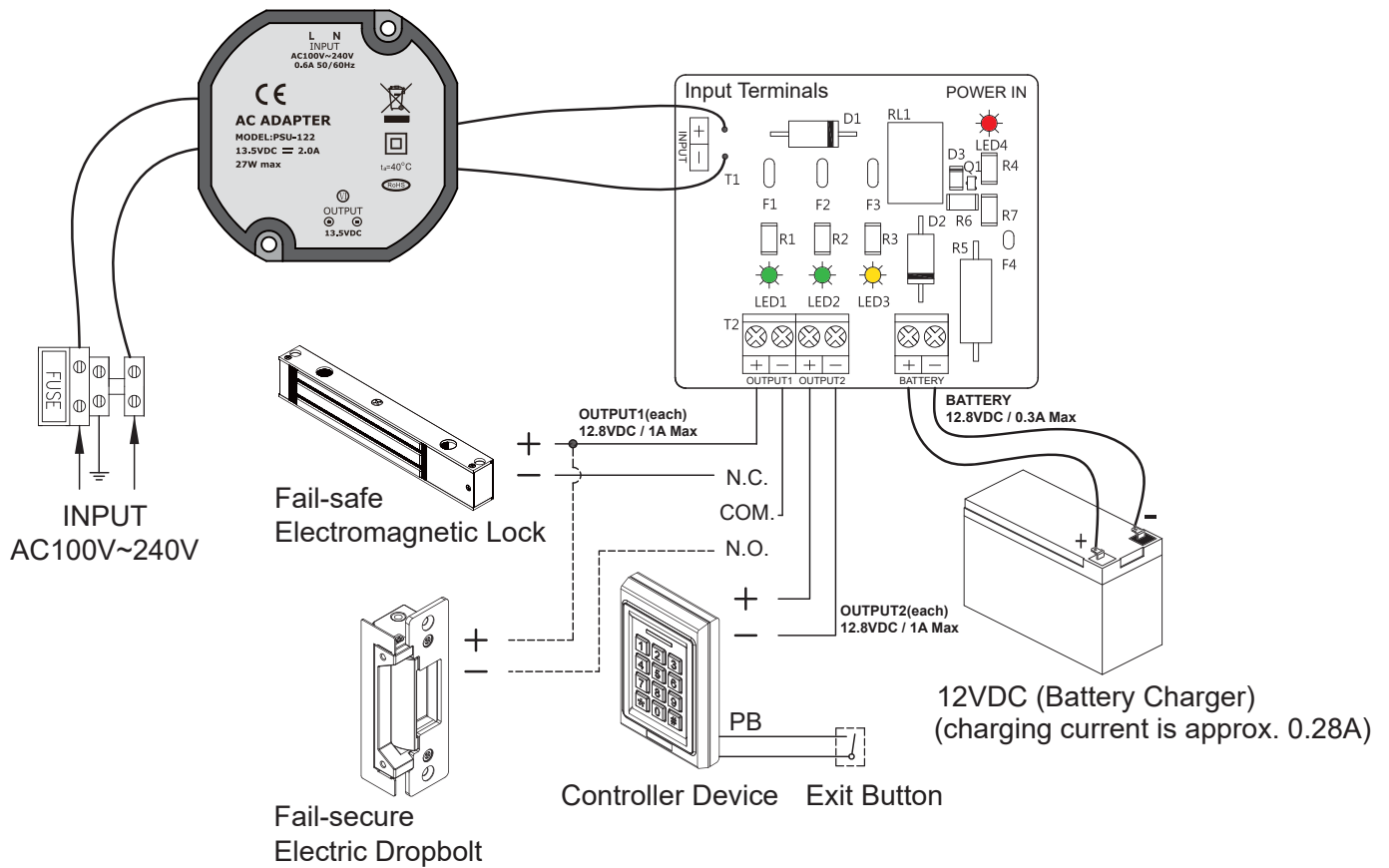

Compatible Bluetooth Keypads

Our line of Bluetooth keypads and proximity readers work together with our full range electric locks. They are designed to make admin and reader configurations more convenient. For more information please refer to relevant product catalog or flyer.

Warranty is extended to 5 years when purchased and installed with PSC-122B.



DG-800⁺



DG-170⁺



DG-320BLE



DG-325BLE

Warranty

The product is warranted against defects in material and workmanship while used in normal service for a period of 3 years from the date of sale to the original customer. The GEM policy is one of continual development and improvement; therefore GEM reserves the right to change specifications without notice.