

# PBH-350DE Delayed Egress Electromechanical Push Bar Installation Instructions

The PBH-350DE Delayed Egress Electromechanical Push Bar is designed for use on emergency exit doors. The built-in electrified lock is designed with its high preload capability that allows smooth operation even under varying loads on the door, such as air-conditioning pressure, changes in the weather, warped doors or doors with weather stripping.

- Operating voltage 12 or 24VDC
- Built-in 95 db piezo alarm
- Nuisance delay setting: 0~3 seconds
- Delay egress setting: 15/30 seconds
- Door ajar input
- Emergency signal input
- Aluminum alloy cover
- Static strength 1500 lbs
- Up to 500 lbs. of preload
- Fail-safe mode

Model	Operating Voltage	Current Draw
PBH-350M-PL-12	12VDC	385mA
PBH-350M-PL-24	24VDC	220mA

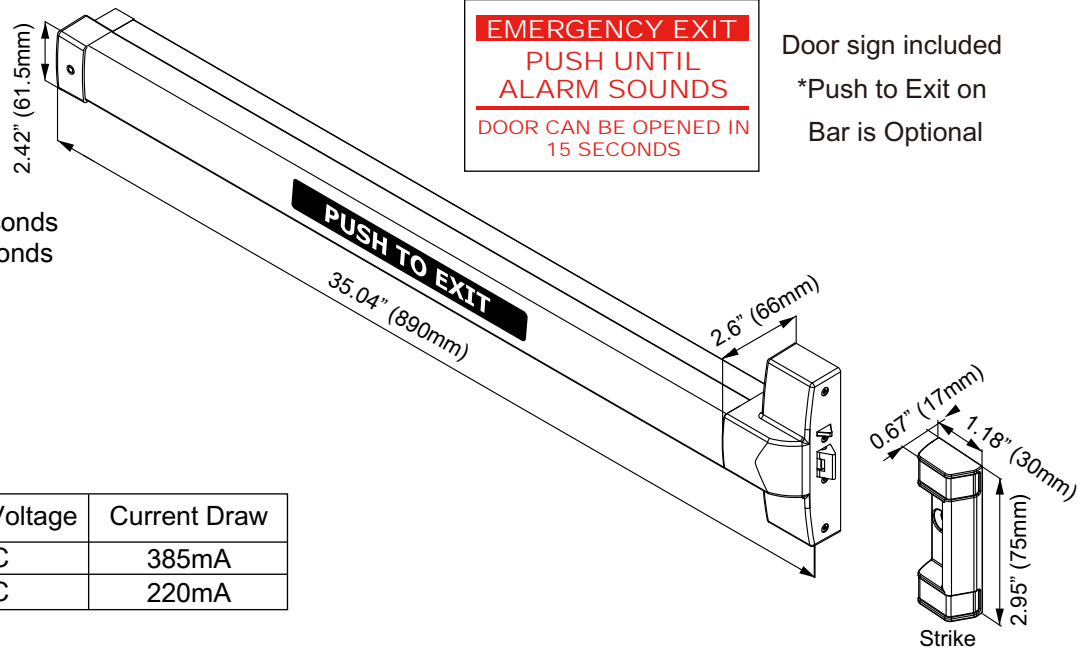

## PBH-350DE Installation Steps

- 1.**

Unscrew and remove the chassis cover.
- 2.**

Unscrew and remove the end cap.
- 3.**

Separate housing assembly and mount the device body horizontally. Reverse step 2, and then step 1.
- 4.**

Connect to power and test the device. Complete the installation.

# PBH-350DE Delayed Egress Electromechanical Push Bar Installation Instructions (Continued)

## PBH-350DE Instructions

Terminal	Connection
RESET	Reset input (Keyswitch)
RESET	
OUT -	Fail-safe electrified lock contacts
OUT +	
V -	Power input 12~24 VDC/AC
V +	
N.C.	Relay contacts for external buzzer Rating: 1A@24VDC, 0.5A/125VAC
COM.	
N.O.	
CUT IN	Emergency signal input (Door Pull /Fire panel system)
CUT IN	

START	Switch signal input (for PBH-350DE push bar)
PASS	Connection to a keypad or reader for authorized egress without sounder
HALL	Door Ajar Input When the door is left open for more than 3 seconds, a door ajar alarm will sound until the door is closed.

## PBH-350DE PC Board Diagram

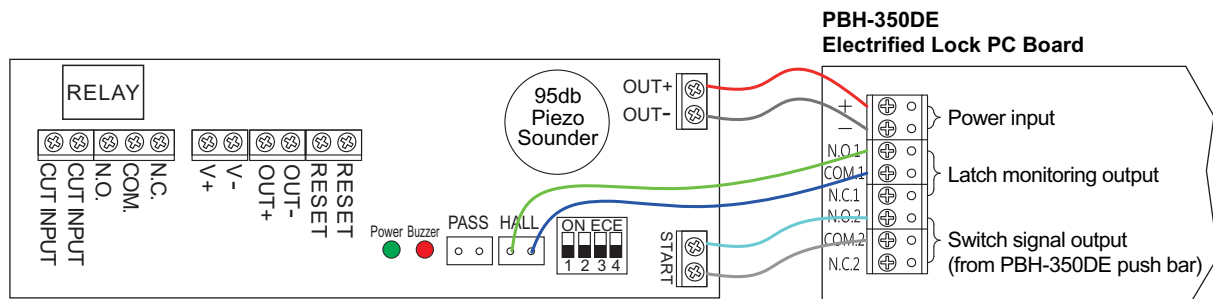

### Nuisance Delay Setting

Setting of the Depressed Time of Push Bar  
*Dip Switch 1 & 2*

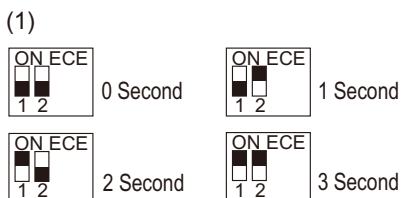

### Delay Egress Setting

*Dip Switch #3*

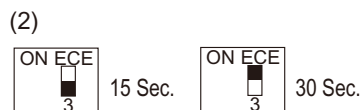

### Emergency Signal Input (N.C. / N.O.)

*Dip Switch 4*

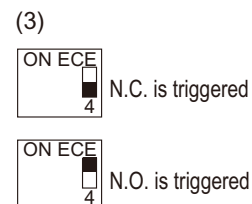

## Operation Notes

- (1) The nuisance delay time can be set to 0 sec, 1 sec, 2 sec, or 3 sec before triggering the piezo alarm when the door remains locked. Set up the time by moving dip switch 1 & 2. *Note: The 0 second nuisance does not include the 200 millisecond de-bounce delay - it was added to eliminate false triggering. The actual delay is 0.2 seconds.*
- (2) When the push bar is pressed, the delay egress count-down begins and the piezo alarm will go off (based on nuisance delay settings). Adjust dip switch #3 to set delay egress to 15 or 30 seconds for locking device to release. Verify with your AHJ (Authority Having Jurisdiction) as to which time you must follow.
- (3) When the emergency signal input (CUT IN) is triggered under emergency circumstances, the magnetic lock on a door will be released to exit immediately. \*Verify if you need this to go into NO or NC Status for Emergency and ensure it is in correct position.

The alarm beeps every single second before the delay egress ends. After the ending of delay egress, the piezo continuously sounds until a RESET is triggered by key switch or other mode of reset. \*The reset function can be used during the egress delay.

The bypass function can be used with access control system to exit the door without putting the PBH-350DE into alarm, by using the PASS input on the PC Board.