

GK231/233 Series Electric Strikes Installation Instructions

Specifications

- Operating Voltage: 12/24 VDC
- Voltage Tolerance: $\pm 10\%$
- Current Draw: 300mA/12VDC ; 150mA/24VDC
- Operating Temperature: + 14°F to + 120°F (-10°C to +49°C)
- Humidity: 0~85% non-condensing
- Solenoid Testing: Over 250,000 cycles
- Preload: Up to 500 lbs.
- Construction: Stainless steel
- Net Weight: 673g
- Latch Throw: GK231: 15mm, GK233: 11mm (With 3mm door gap)
- Keeper Width: 48mm
- Lock Mode: Fail-safe

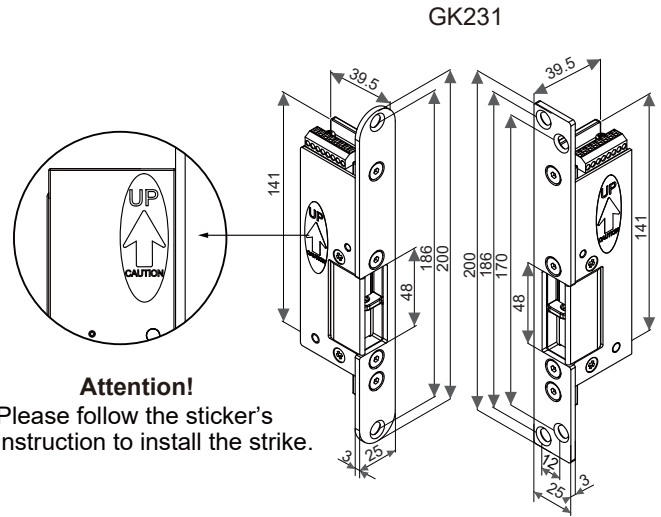

Keeper Adjustment (GK233 Only)

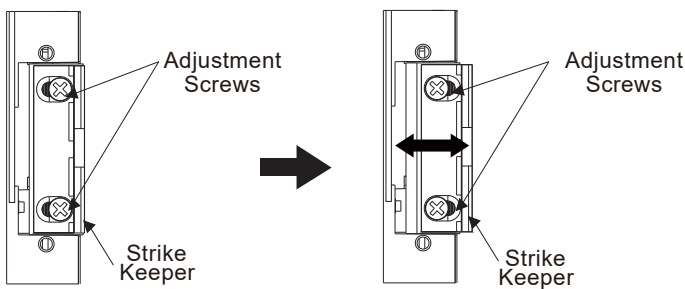

The strike keeper can be adjusted horizontally to account for various installation anomalies. To adjust the keeper, loosen the adjustment screws, move the keeper horizontally as needed, and retighten the adjustment screws.

(Maximum adjustable range: 3mm)

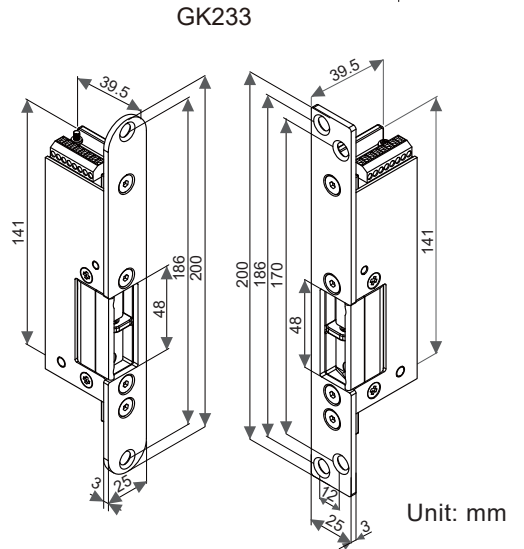

Handing Guide

Door handing is determined from the side of the door where the hinges are visible, according to the German standard DIN 107.

Stand facing the door on the hinge / pull side. If the hinge is on the right, the door is considered to be DIN right. If the hinge is on the left, then the door is considered to be DIN left.

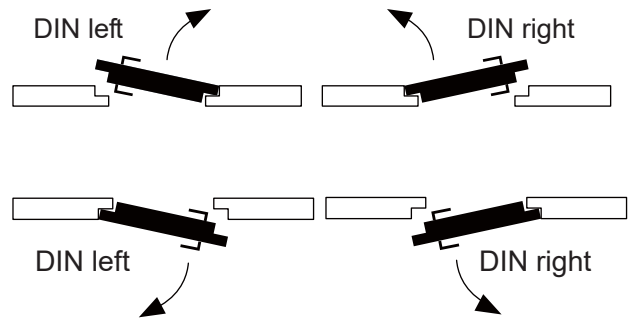

Models (M: Door Status Monitor & Lock Status Monitor)

DIN left		DIN right	
GK231L-1224	GK233L-1224	GK231R-1224	GK233R-1224
GK231ML-1224	GK233ML-1224	GK231MR-1224	GK233MR-1224

Voltage Selection

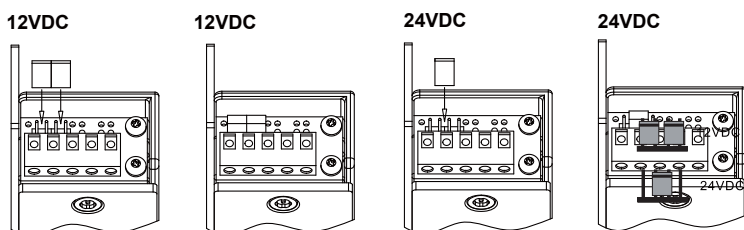

Voltage Selection Jumpers

Check jumper settings before connecting the lock to 24VDC input power. Damage to the lock may result from incorrect jumper settings.

Optional Brackets

Lip extension brackets are available for wider jambs.

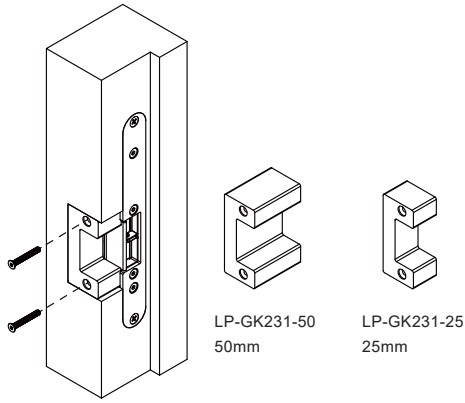

Mortise Mount in Wooden Frame

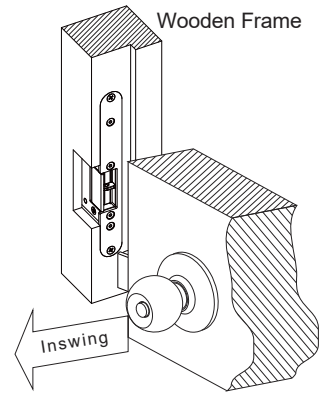

Wiring Diagram

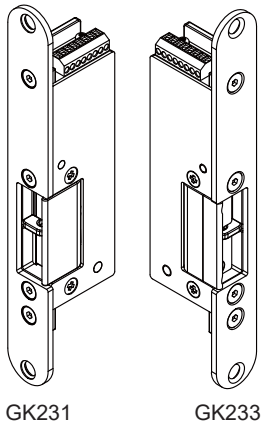

GK231

GK233

Operating Voltage

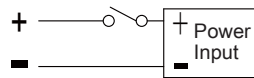

Lock Status Output

N.O.2
C.2
N.C.2

N.C. contact output: unlocked status
N.O. contact output: locked status

Lock status output 1/125VAC

Door Status Output

N.O.1
C.1
N.C.1

N.O. contact output: open status
N.C. contact output: closed status

Door status output 1/125VAC

Installation Steps

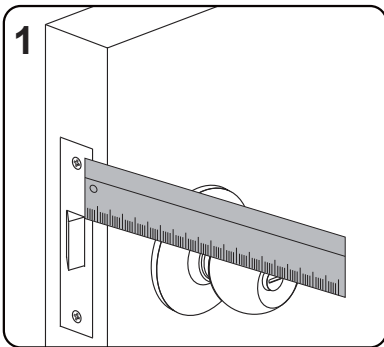

1 Measure the vertical and horizontal position of the latch bolt on the door leaf.

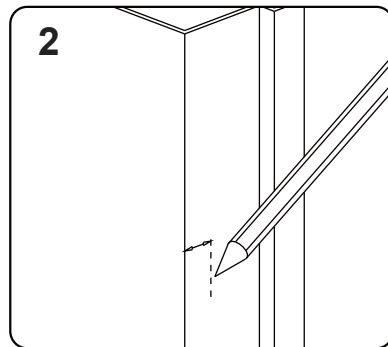

2 Mark the position of the latch bolt on the door frame as shown in the figure.

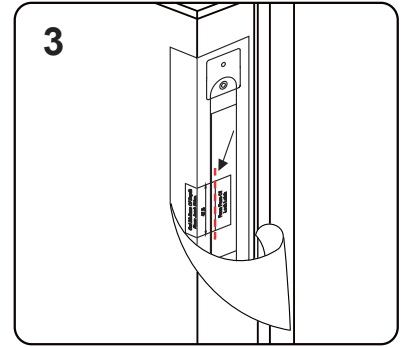

3 Mount the supplied template and align to the marked line.

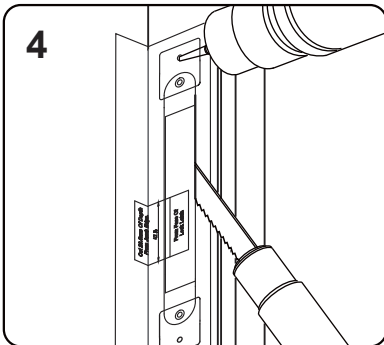

4 Drill and cut the frame according to the template.

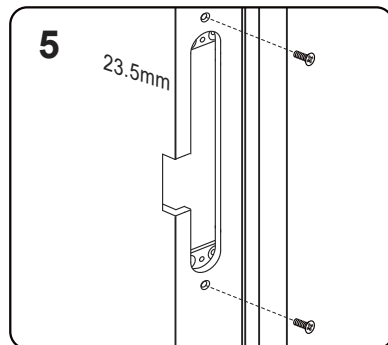

5 Tighten the indicated screws.

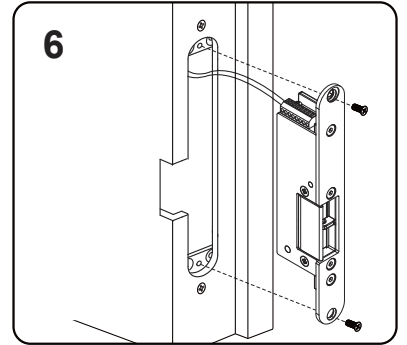

6 Connect the wires and install the strike.



Note

It must be ensured that there is a small space between the latch bolt and actuated latch stop when the door is closed and the latch bolt is in its locked position. This will relieve pressure on the solenoid valve and reduce the risk of failure when opening the door.