

Split Series

Access Touch Keypad

with Proximity Card Reader
Installation & Programming
Manual

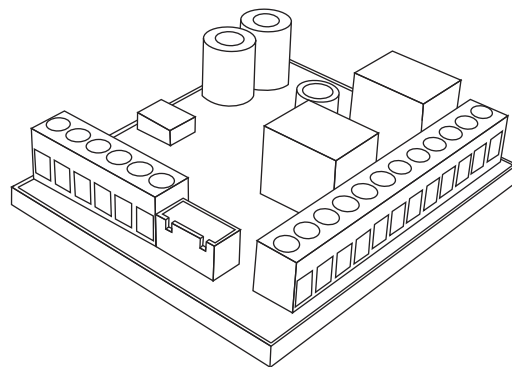
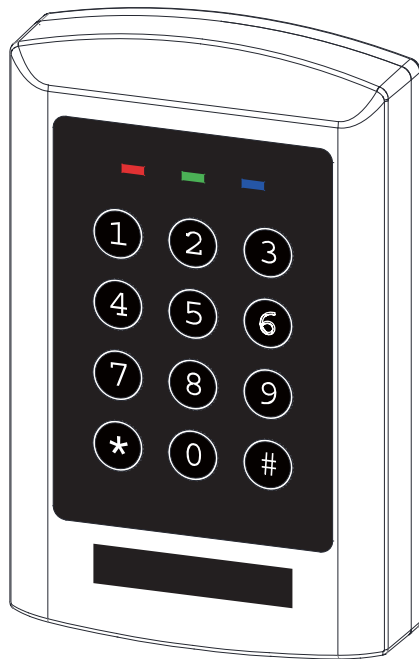

Model	Technology	Keypad	Mount	Logo/ Trademark	Indicator Light
DG-350	EM 125KHz Proximity	Tactile Keys	Single Gang Surface/Flush	Poly Nameplate	3 LEDs
DG-700	EM 125KHz Proximity	Tactile Keys	Single Gang Surface	Poly Nameplate	Multi-Colored LED
DG-760	EM 125KHz Proximity	Tactile Keys	Mullion Surface	Poly Nameplate	Multi-Colored LED
DG-770TP	EM 125KHz Proximity	Touch Panel	Single Gang Surface	Red LED Display	3 LEDs

Split controller prevents magnetic interference
with the access control unit to prevent
unauthorized entry into the building

Please read the manual carefully before use this unit

◆ Features

- Accept power from a 12 or 24 Volt AC/DC supply
- Up to 1,000 user codes (000~999) programmable for output#1 and 10 (00~09) for output#2
- 2 Form C relays, each rated 10A@30VDC
- Each relay has programmable output time from 1~99 seconds or toggle
- Output #2 can be programmed for use with a door bell
- 2 Egress inputs for exiting the premises without keying in the code
- Split controller installation protects the keypad access from magnet tampering
- Tactile key feel and blue backlit 3x4 keypad for easy nighttime use (For DG-700/760)
- All features are programmed entirely from the keypad.
- Non-volatile EEPROM protects codes and instructions in case of power loss
- Tamper contact for added security (N.C. Dry contact, 100mA@12VDC max.)
- High strength design, epoxy potted, fully sealed within a zinc alloy housing
- Built-in RFID proximity reader

◆ Specifications

Operating Voltage		12~24 VAC/VDC			
Current draw	Model	Voltage	Holding	Pull in	Keypad Light On
	DG-700	12VDC	50mA	103mA	50mA
		24VDC	30mA	56mA	30mA
	DG-760	12VDC	50mA	95mA	50mA
		24VDC	30mA	50mA	30mA
DG-770TP	12VDC	27mA	95mA	41mA	
	24VDC	18mA	50mA	26mA	
Relay Outputs	Total max. current draw	10mA@30VDC, Form C, NO/NC/COM			
	Total max. current draw	10mA@30VDC, Form C, NO/NC/COM			
Egress Inputs	Total max. current draw	N.O. Ground			
	Total max. current draw	N.O. Ground			
Operating Temperature		-4°~122°F (-20°~50°C)			
Proximity reader frequency		125kHz			
Proximity reader distance		1.2" (3cm)			

◆ Audible Indicators

Audible Tone	Keypad Status
1 Long tone	Confirmation
1 Short tone	Key press
3 short tone	User code denied
6 short + 1 long tone	All user codes deleted

◆ LED Indicators

LED	Keypad Status
Steady Amber	Programming Mode
Flashing Amber	Waiting to programming entry
Steady Green (Also flashing amber: DG-770TP)	Waiting to program card/code
Steady Red (Also flashing amber: DG-770TP)	Card/Code already present
Steady Green	Relay 1 activated
Steady Red	Relay 2 activated
Flashing Amber (6 flashes, for DG-770TP)	Reconnect power

◆ Dimensions

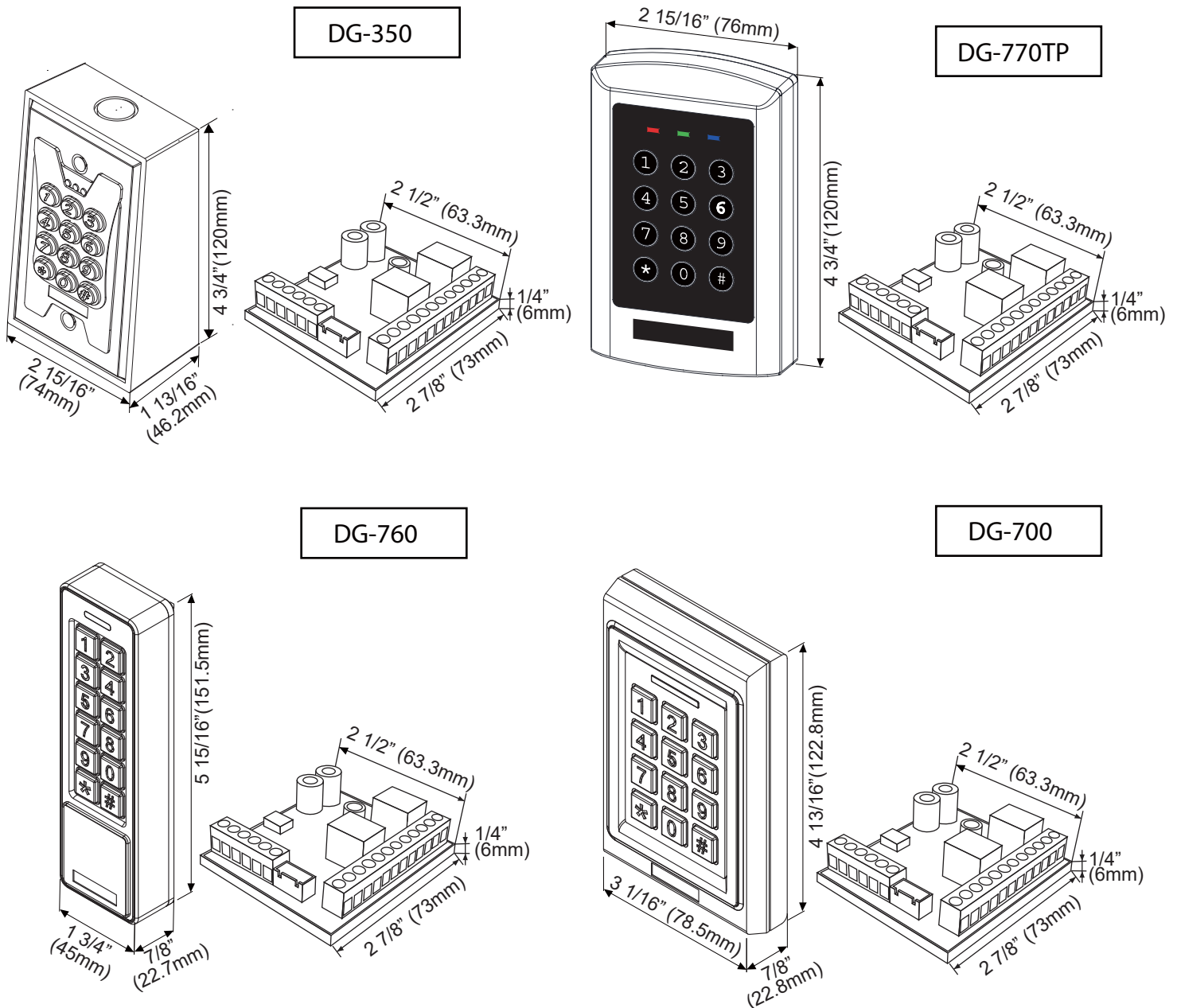

◆ Sample wiring and applications

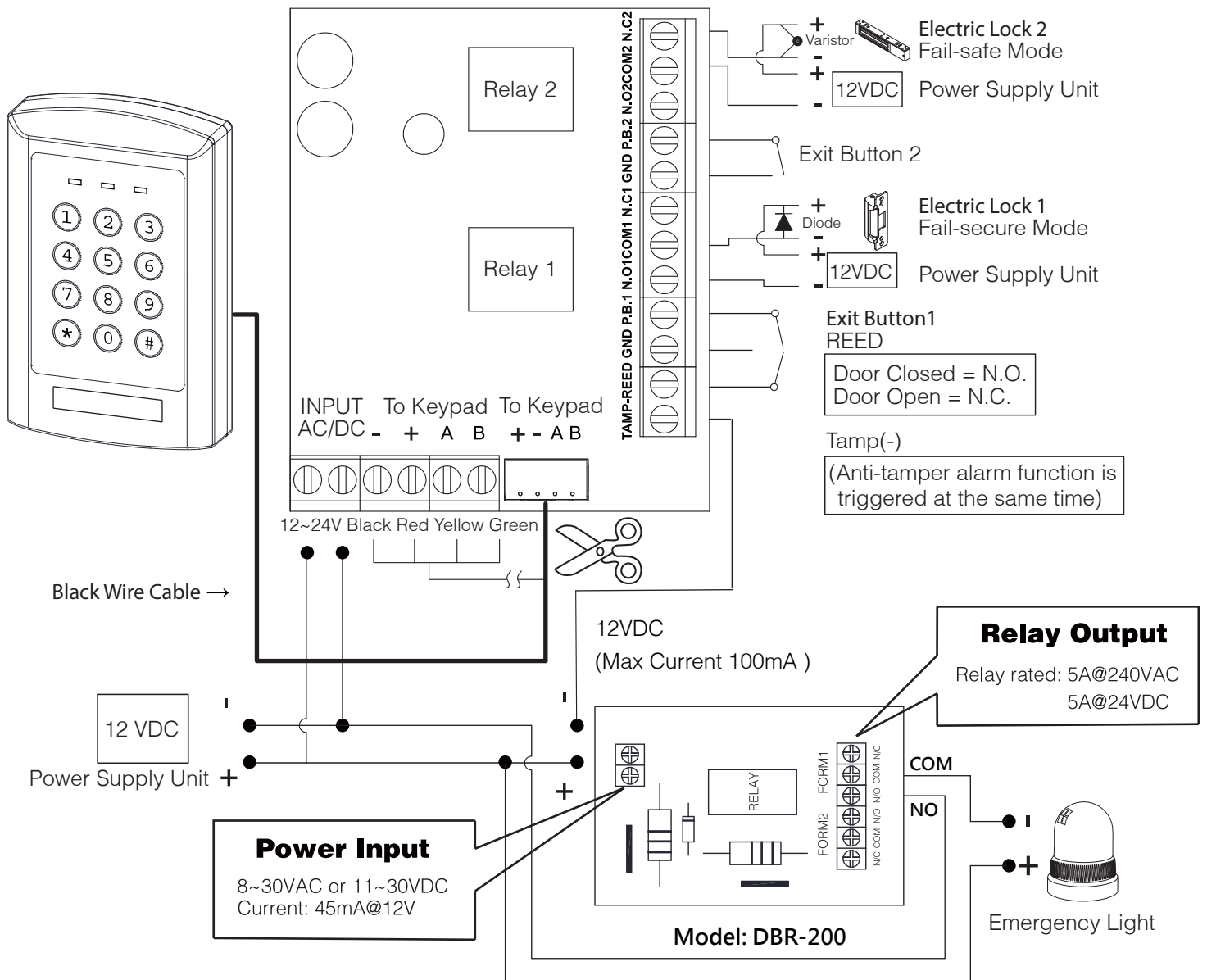

◆ Programming Instructions

- Codes are programmed to be 4~6 digits in length. All codes must be the same length.
- Before inputting any of the following, enter Programming Mode by entering the Master Code twice.
The default master code is 1234.
To enter Programming Mode, enter **1 2 3 4 1 2 3 4**
- To exit Programming Model, press the **#** key.
- The keypad will exit Programming Mode if no keys are pressed for 30 seconds.

◆ Programming Tips

- Program a new Master Code immediately.
- Take note of the keypad status LED –
 - Right LED Solid Amber: Programming Mode
 - Middle LED Solid Green / Right LED Flashing Amber: Awaiting code/card entry
- If you are unsure of which mode the keypad is in, press **#** until the right LED is off. The keypad is now in the Standby Mode. Enter the master code twice to return to Programming Mode..

◆ First Time Keypad Use

Take these steps the first time the keypad is programmed.

A. Enter Programming Mode

Enter **1 2 3 4 1 2 3 4** (Default Master Code is 1234)

B. Program Code Length

NOTE: To keep the default 4-digit code length, skip to step C, Program the Master Code.

WARNING: After a new code length is programmed, all user codes will be deleted and the master code will be reset.

1. Enter Programming Mode by entering the Master Code twice. (Default Master Code is 1234).

2. Enter *** 9 0 4**

3. Enter the desired code length. This must be a number from 4~6.

4. Exit Programming Mode by pressing **#**.

The Master Code will reset depending on the programmed code length. These will be the new Master Codes after the code length is reset:

Code Length	New Master Code
4 digits	1234
5 digits	12345
6 digits	123456

C. Program the Master Code

1. Enter Programming Mode by entering the Master Code twice. (Default Master Code is 1234).

2. Enter *** 3**

3. Enter the new Master Code twice. The Master Code may not be the same as a user code.

Example: If the desired new Master Code is 4321, enter **4 3 2 1 4 3 2 1**

4. Exit Programming Mode by pressing **#**.

D. Program the Master Card

In addition to a Master Code, a Master Card can also be programmed. Swiping a Master Card will give direct access to Programming Mode.

1. Enter Programming Mode by entering the Master Code twice. (Default Master Code is 1234).

2. On the keypad, enter *** 7**.

3. If the middle LED is solid green and the right LED is flashing amber, a Master card is already programmed. Clear it by entering *** ***. The keypad will beep in confirmation, the middle LED will start flashing green and the right LED will start flashing amber.

4. Swipe a proximity card. This card is now the Master Card.

5. Exit Programming Mode by pressing **#**.

E. Setting the Output #1 Access Mode

DEFAULT: User card OR user code.

1. Enter Programming Mode by entering the Master Code twice.
2. On the keypad, enter ***0**.
3. Enter one of the following:
 - 00** User card only
 - 01** Either user card or user code (DEFAULT)
 - 02** Use card and user code

NOTE: Deleting all users is recommended before changing the access mode to user card with user code.

4. Exit Programming Mode by pressing **#**.

◆ Programming Output #1:

Each Output #1 user can be programmed to have a user card, a user code, or both user card and code.

NOTE: For all of the following programming functions, the keypad must be in Programming Mode. To enter Programming Mode, enter the Master Code twice.

A. Program User Cards

1. Enter a user ID number (**000** to **999**)
2. If the left LED is red, previous user data exists. Clear it by entering ******. The keypad will beep in confirmation and the middle LED will turn green.
3. Swipe a new user card.
4. To program the next user, repeat from step 1 in section A, B or C.
5. Exit Programming Mode by pressing **#**.

B. Program User Codes

1. Enter a user ID number (**000** to **999**)
2. If the left LED is red, previous user data exists. Clear it by entering ******. The keypad will beep in confirmation and the middle LED will turn green.
3. Enter a new user code.
4. To program the next user, repeat from step 1 in section A, B or C.
5. Exit Programming Mode by pressing **#**.

C. Program Both User Cards and Codes

1. Enter a user ID number (**000** to **999**)
2. If the left LED is red, previous user data exists. Clear it by entering ******. The keypad will beep in confirmation and the middle LED will turn green.
3. Swipe a new user card.
4. Enter a new user code.
5. To program the next user, repeat from step 1 in section A, B or C.
6. Exit Programming Mode by pressing **#**.

◆ Programming Output #2:

Each Output #2 user may only have a user card or a user code programmed.

NOTE: For all of the following programming functions, the keypad must be in Programming Mode. To enter Programming Mode, enter the Master Code twice.

A. Programming an Output #2 User Card

1. Enter [*][4].
2. Enter a user ID number ([0][0] to [0][9])
3. If the left LED is red, previous user data exists. Clear it by entering [*][*]. The keypad will beep in confirmation and the middle LED will turn green.
4. Swipe a new user card.
5. To program the next user, repeat from step 2 in section A or B.
6. Return to Programming Mode by pressing [#].
7. Exit Programming Mode by pressing # again.

B. Programming an Output #2 User Code

1. Enter [*][4].
2. Enter a user ID number ([0][0] to [0][9])
3. If the left LED is red, previous user data exists. Clear it by entering [*][*]. The keypad will beep in confirmation and the middle LED will turn green.
4. Enter a new user code.
5. To program the next user, repeat from step 2 in section A or B.
6. Return to Programming Mode by pressing [#].
7. Exit Programming Mode by pressing # again.

◆ Deleting or changing users and cards:

Deleting or Changing the Master Card

Step 1 Enter: [*][7]

Step 2 Delete the existing Master Card by entering: [*][*]

Step 3 Swipe a new Master Card or Exit Programming Mode by entering [#].

Deleting or Changing an Output #1 User:

Step 1 Enter a user ID number: [0][0][0] to [9][9][9]

Step 2 Delete existing user by entering: [*][*]

Step 3 Swipe a new user card or Enter a new user code [X][X][X][X] or Return to Programming Mode by entering [#].

Deleting or Changing an Output #2 User:

Step 1 Enter: [*][4]

Step 2 Enter a user ID number: [0][0] to [0][9]

Step 2 Delete existing user by entering: [*][*]

Step 3 Swipe a new user card or Enter a new user code [X][X][X][X] or Return to Programming Mode by entering [#].

◆ Using the Keypad:

Using a User Card with a User Code

- If Output #1 is programmed to accept a user card with a user code, swipe the user card. Immediately enter the user code. This may be done in reverse order.

Wrong Code Lockout

- If a wrong code is entered or an invalid card is swiped 5 consecutive times, the keypad will go into lockout for 1 minute. During this time, no codes can be entered and no card can be swiped. (For DG-350 and DG-770TP, the keypad sounds 3 beeps and red LED flashes 3 times)
- Pushing buttons or swiping cards during lockout will extend the lockout time.
- When the keypad is reset to factory default state, keypad light flashes once for code re-entry. (For DG-350 and DG-770TP)

◆ Additional Programming:

Programming the Output# 1 Timer

DEFAULT: 1 second

Step 1 Enter: * 1

Step 2 For toggle mode, enter 00 or for timed output, enter 01 to 99

01 to 99 is the number of seconds Output #1 will activate

Programming the Output# 2 Timer

DEFAULT: 1 second

Step 1 Enter: * 5

Step 2 For toggle mode, enter 00 or for timed output, enter 01 to 99

01 to 99 is the number of seconds Output #1 will activate

Programming the Output# 2 Function

Output #2 can be activated via * or through user codes. Use the following steps to program its function.

DEFAULT: User Codes

Step 1 Enter: * 2

Step 2 For user codes, enter 01 or for door bell, enter 02

When output #2 is programmed for doorbell, press to activate doorbell. Doorbell output lasts 1 second.

◆ RESETTING THE KEYPAD:

NOTE: Resstting the keypad will cause some or all programmed data to be lost. Do not perform either of these steps unless it is absolutely necessary.

Deleting All Users: Enter * 8 8 8

IMPORTANT: Once key entry is made, all user cards and user codes will be deleted and the keypad will return to Programming Mode. The Master Code and all other programming settings will remain the same.

Restore Factory Settings: Enter * 8 9 9

IMPORTANT: Once key entry is made, keypad will return to factory default settings. No user information will be retained and the Master Code will be 1234.

◆ MANUALLY RESETTING THE MASTER CODE:

If the Master Code has been forgotten or does no work, the following steps can be taken to reset the Master Code:

1. Disconnect power from the keypad.
2. Press the # key continuously and connect power again.
3. The keypad will beep to confirm a successful reset.

Note: Manually resetting the Master Code will only reset the Master Code. It will not affect the Master Card, User Code or any other saved data.