

DG-187

Digital Keypad Separated Controller System Operation Manual

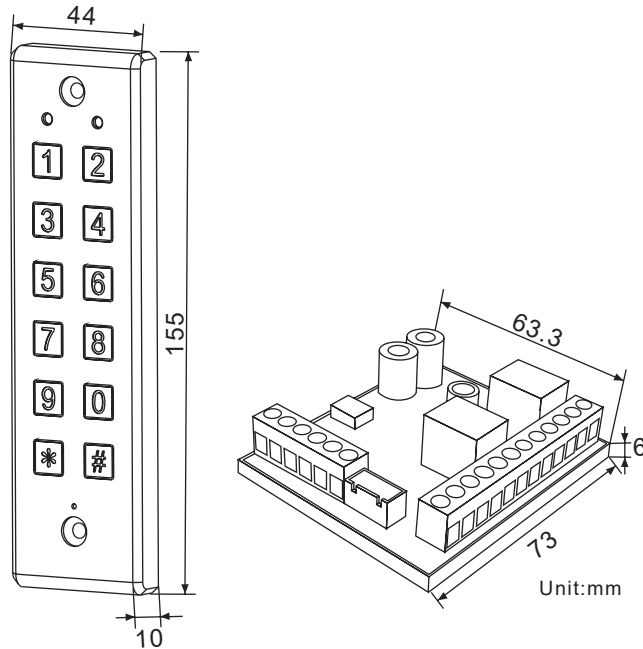

■ Features:

1. Epoxy sealed for waterproof function (IP65).
2. Designed with piezoelectric keypad.
3. Built-in light sensor detection switch for vandal resistance.
4. Digital keypad separated control system designed to enhance security.
5. Aluminum alloy casing with vandal resistant screws for enhanced safety and durability.
6. Allows up to 1000+10 PINs.
7. The controller will be locked for 60 seconds upon 5 consecutive invalid PINs.
8. Controller with keypad sound to avoid incorrect key-in.
9. Additional input for anti-tailgating function to ensure high security access control.
10. Non-volatile memory control can retain all PIN codes in event of power failure.
11. Dual relays for electric lock devices and other access control systems.

■ Specifications

Operating Voltage	12~24VAC/VDC
Current Draw	Pull in: 120mA/12 VDC : Holding: 60mA/12 VDC Pull in: 70mA/24 VDC : Holding: 40mA/24 VDC
Keypad	6X2 matrix keypad (0~9 , * , #)
Input	2 contacts for Request-To-Exit buttons
	1 contact for Door Status Sensor
	1 contact for Anti-Tamper Alarm Tamp (-)
Output	2 relays (N.O./COM./N.C.)
LED Status Indication	2 LEDs – 4 Colors (Blue/Green/Yellow/Red)
Memory Volume	1000+10 PINs
Relay Rating	Max. 3A/30 VDC
Relay Strike Time	01~99 seconds or manual mode(00)
Ambient Humidity	5%~95% (Non-condensing)
Operating Temperature	-20°C~60°C

■ Status Indications & Default Setting Parameters

Beep & LED Indications:

	Mode	Signal	Status
LED	Standby	Blue Indicator On	Power on, Standby
		Green Indicator On	First Relay Activated
		Red Indicator On	Second Relay Activated
	Programming	Yellow Indicator On	Programming Mode Entry
		Green Indicator On	The slot position of first relay is available
		Red Indicator On	The slot position of first relay is unavailable
Green Indicator On		The slot position of second relay is available	
		Red Indicator On	The slot position of second relay is unavailable
Beep	Standby	1 Beep	Key entry, and Enter Programming mode
		2 Beeps	Incorrect PIN
	Programming	1 Beep	Correct input data, and Exit Programming mode
		3 Beeps	Incorrect input data or Other invalid operation

Factory Default Setting:

Master Code	1234(4 digits), Capable for 4~6 digits in length
Relay Strike Time	1 second
Pressed Key Time Delay	5 seconds (fixed)
Programming Mode Time Delay	30 seconds (fixed)

■ Wiring Diagrams

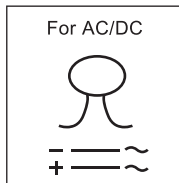
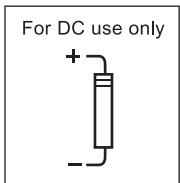
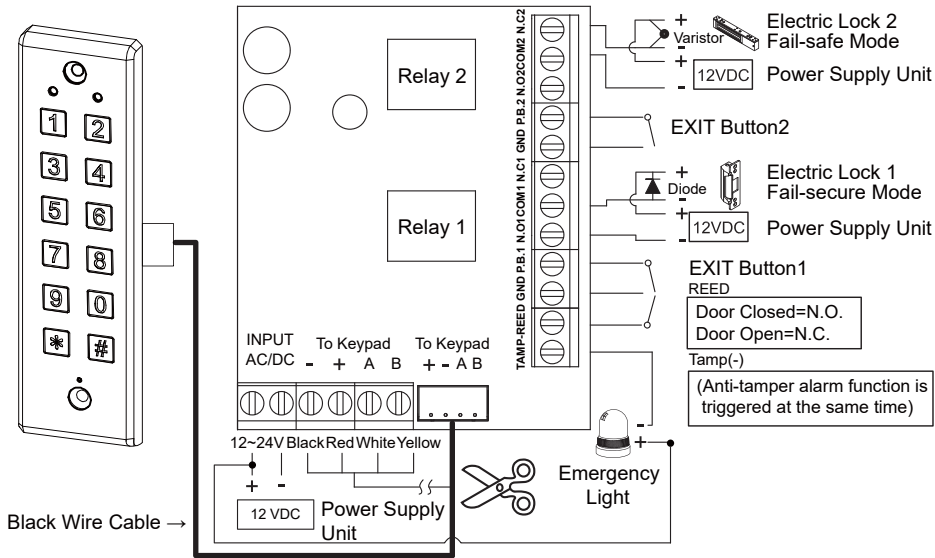

PBT-800	European Standard Size
AS-500	ANSI Size

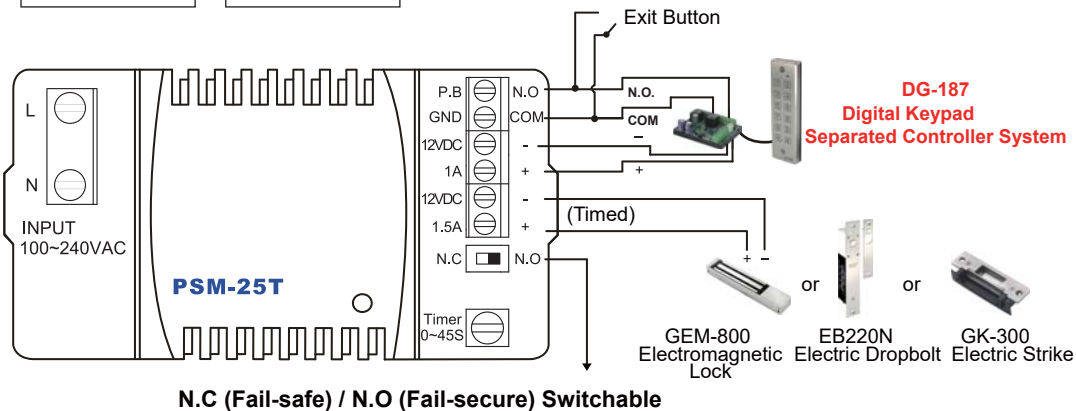

Note:

1. It is suggested to use a linear power supply unit to prevent power rating reduction from the keypad.
2. It is suggested to use #22~26 AWG insulation wire.
3. Exit button is at N.O. contact.
4. With CE qualified EMC specification.
5. The door strike or relay must have a varistor or a diode across the door strike terminals to suppress the back EMF of the strike – failure to do so will damage the relay contacts and electronic components, or even burn the controller.
6. When the digital keypad controller supplies power, please wait until Green LED flashes (8 beeps and Blue LED is on) to enter Standby Mode.
7. Anti-Tamper Alarm output Tamp(-): DC12V/100mA (-) output. It is capable to connect with an alarm buzzer or a caution light, and triggered the anti-tamper alarm function at the same time. Tamp (-) is N.C. output, and when it is triggered, it becomes N.O. output.
8. When the keypad wire is not long enough, cut off the black wire (with the white color wire head), and you can make the extension wire on your own.

■ Operation Instructions

1. Master Code

The master code comprises a four-digit code and is used to access programming functions of the digital keypad and cannot be used for access request i.e. it cannot be the same as other PINs. The default master code is 1234. Under normal operation, entering PINs will gain access. In the programming mode, the keypad can be used to add/delete PINs, set relay strike time and other operation functions.

2. Entering Programming Mode

Enter the master code twice 1234, 1234 to enter Programming Mode (1 beep and Yellow LED is on).

3. Setting Relay Strike Time

The relay strike time determines the amount of time that the door remains unlocked after a valid PIN is entered.

- a. Enter Programming Mode.
- b. Press * 1 for Relay 1 (Yellow LED flashes).
Press * 5 for Relay 2 (Yellow LED flashes).
- c. Press 00-99 (1 beep and Yellow LED is on).
- d. Press # (1 beep) to be back to Standby Mode (Blue LED is on).

NOTE: For both Relay 1 & Relay 2, entering 00 will set relay strike time to 0 second. Entering 05 indicates 5 seconds and so on.

4. Clearing Memory of All PINs

- a. Enter Programming Mode.
- b. Press * 8 (Yellow LED flashes).
- c. Press 88 (Yellow LED is on and 7 beeps).
- d. Press # (1 beep) to be back to Standby Mode (Blue LED is on).

5. Resetting Controller Parameters to Factory Default Value

- a. Enter Programming Mode.
- b. Enter * 8 (Yellow LED flashes).

- c. Enter 99(1 beep, and Green LED flashes) to be back to Standby Mode(Blue LED is on).

6. Adding PINs to Relay 1

- A.**
- a. Enter Programming Mode.
 - b. Enter a slot position 000-999(Green LED will be on to indicate the slot position is available).
 - c. Press 4- digit PIN (1 beep, and Yellow LED is on).
 - d. Press # (1 beep) to be back to Standby Mode(Blue LED is on).

NOTE: Master Code Must be Not be the same as PINs.

- B.**
- a. Enter Programming Mode
 - b. Enter a slot position 000-999 (Red LED will be on to indicate the slot position is unavailable).
 - c. Press ** (1 beep) to delete the data from the slot position (Green LED is on).
 - d. Press # (Yellow LED is on) to be back to Programming Mode.
 - e. Repeat Step 6–A to add a new PIN.

7. Adding PINs to Relay 2

- A.**
- a. Enter Programming Mode.
 - b. Press * 4 (Yellow LED flashes).
 - c. Enter a slot position 00-09(Green LED will be on to indicate the slot position is available).
 - d. Press 4- digit PIN (1 beep, and Yellow LED is on).
 - e. Press # (1 beep) to be back to Standby Mode (Blue LED is on).

- B.**
- a. Enter Programming Mode.
 - b. Press * 4 (Yellow LED flashes).
 - c. Enter a slot position 00-09(Red LED will be on to indicate the slot position is unavailable).
 - d. Press ** to delete the data from the slot position (1 beep, and Green LED is on).
 - e. Press # to be back to Programming Mode (Yellow LED is on).
 - f. Repeat Step 7-A to add a new PIN.

8. Changing Master Code

- a. Enter Programming Mode.
- b. Press * 3 (Yellow LED flashes).
- c. Enter 4-digit master code twice i.e. 4567 4567(1 beep, and Yellow LED is on).
- d. Press # (1 beep) to be back to Standby Mode (Blue LED is on).

9. Turning Anti-Tamper Alarm Function ON/Off (Default setting is ON).

- a. Enter Programming Mode.
- b. Press * 6 (Yellow LED flashes).
- c. Press 01 (1 beep, and Yellow LED is on)-function OFF.
Press 02 (1 beep, and Yellow LED is on)-function ON.
- d. Press # (1 beep) to be back to Standby Mode (Blue LED is on).

10. Turning Lock-out Function ON/OFF (Default setting is ON)

- a. Enter Programming Mode.
- b. Press * 7 (Yellow LED flashes).

- c. Press 01 (1 beep, and Yellow LED is on)-function OFF.
Press 02(1 beep, and Yellow LED is on)-function ON.
- d. Press # (1 beep) to be back to Standby Mode (Blue LED is on).

11. Changing the Length of Master Code

- a. Enter Programming Mode.
- b. Press * 9 (Yellow LED flashes).
- c. Press 04.
- d. Set up the length of Master Code: Press 4 to set up the length as 4 digits, press 5 as 5 digits, or press 6 as 6 digits (7 beeps and Yellow LED is on).
- e. Press # (1 beep) to be back to Standby Mode (Blue LED is on).

12. Resetting Master Code to Default Value

- a. Turn off power and energize again (Green LED flashes).
- b. Enter # # # # # to be back to Standby Mode (Blue LED is on). Then the master code is reset to default value.
(If the default value is 4 digits, Master Code is 1234, if 5 digits, 12345; if 6 digits, 123456).

Appendix

User	User Name	Slot Number	PIN#
1			
2			
3			
4			
5			
6			
7			
8			
9			
10			

Warranty:

The product is warranted against defects in material and workmanship while used in normal service for a period of 1 year from the date of sale to the original customer. The GEM policy is one of continual development and improvement; therefore GEM reserves the right to change specifications without notice.