



Product Features:

- ✓ Adjustable latch throw(10~19mm)
- ✓ Applicable to GK series electric strikes
- ✓ For wooden doors
- ✓ Stainless steel faceplate , zinc alloy main stand
- ✓ For single-swing doors (left or right)

Statement

Matching electric strikes, the LS-2000 latch set has been upgraded by using zinc alloy casing instead of common metal, and, with stainless steel made adjustable latch throw which enhances security and allows wider door gap during installation.

Wood Frames Mortise Mount

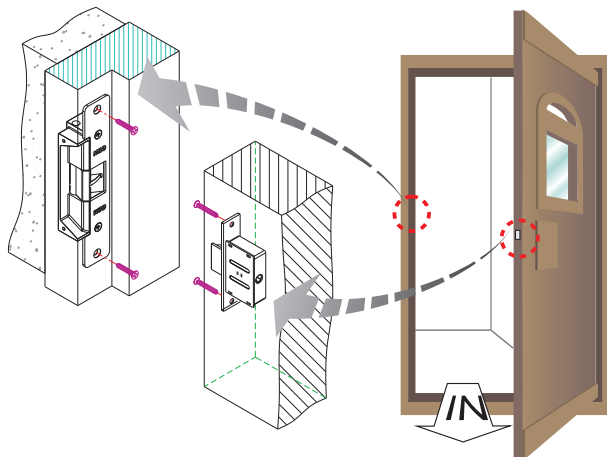

Dimensions

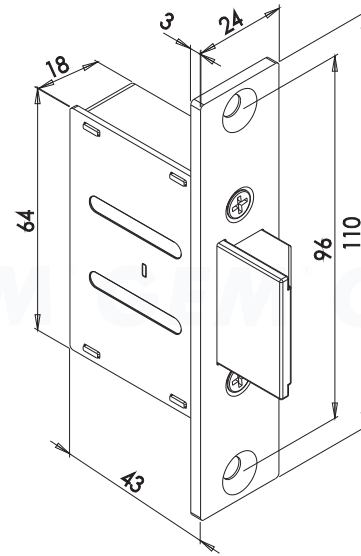

Unit: mm

Adjustable latch throw

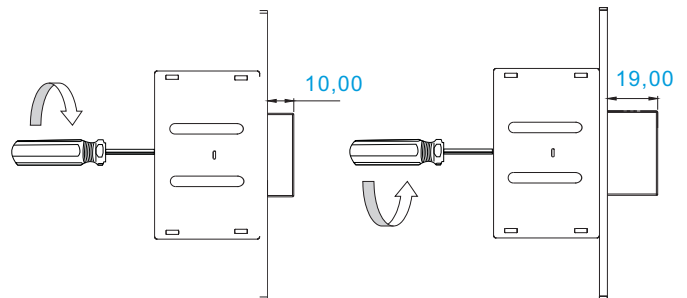

Shorten the latch throw by turning clockwise , or extend it by turning anti-clockwise

GIANNI INDUSTRIES, INC.