



### Statement

The CP-15 series Break Glass call point, with single pole change over contacts from N/C to N/O. The main function is to override the electrical locking/release devices in case of emergency. With Key to replace glass or reset unit.

The Break Glass call point comes with hinged front cover & no needs to power in contact switch for monitoring N/C change over N/O to override electrical locks / release devices for emergency with key to replace glass.

### Specifications

Dimensions: 88x88x52 mm  
 Contact Resistance: 150mΩ  
 Switch rated: 3A@125VAC~  
 Current Draw (Back light):25mA@12Vdc; 45mA@24Vdc

### Dimension

Unit: mm  
 (Common Europe Sized)

Polycarbonate  
 Hinged Cover

Built-in Key  
 (for change break glass)

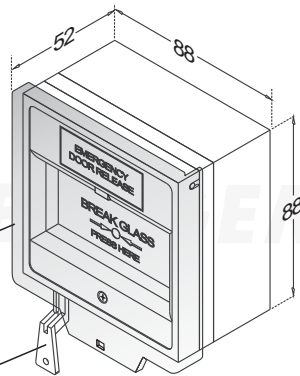

### Application

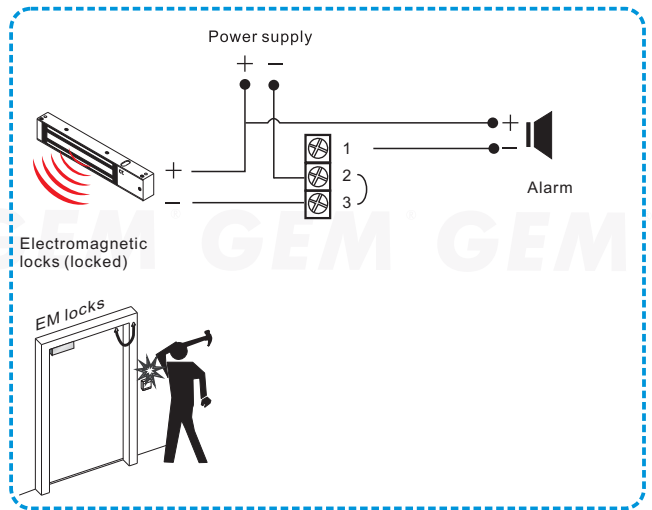

↓ (Glass is broken)

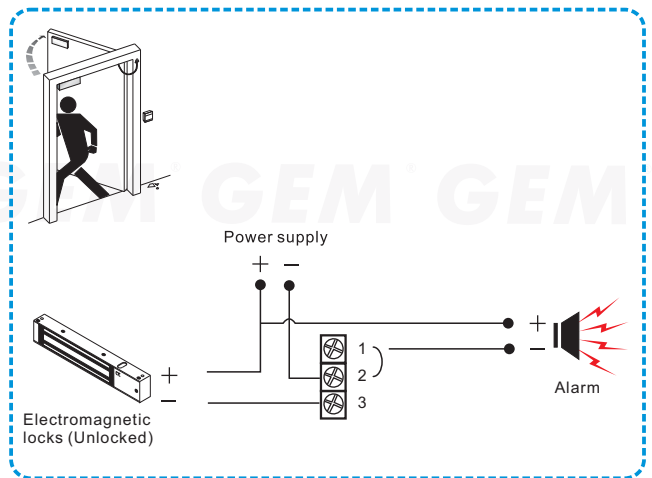

### Warranty

The product is warranted against defects in material and workmanship while used in normal service for a period of 1 year from the date of sale to the original customer. The GEM policy is one of continual development and improvement; therefore GEM reserves the right to change specifications without notice.

### GIANNI INDUSTRIES, INC.

No.306-1, Hsin Shu Road, Hsin Chuang, Taipei, Taiwan 242  
 TEL: 886-2-2206 9929 FAX: 886-2-2204 6632  
 E-Mail: info@gianni.com.tw  
 Website: gianni.tw

Copyright © 2008 Gianni industries, inc. All rights reserved.  
 DM-CA-CP-15 Ver. B Published on 2008.04.29



The products are manufactured under an ISO 9001 & QC 080000 Certified Quality Management Program environment back its product quality, performance and commitment to customer satisfaction.