

Digital Keypad System

Standalone DG Series

DG-101 Standard Flush/Surface Mount Keypad



DG-101-BA



DG-101-WI



Standard US Single Gang Back Boxes (Option)



SMB-101-BA



SMB-101-WI

Standard Features

- Red, yellow, green LED indicators and built-in buzzer for status programming feedback
- Door sensor input for anti-tailgating operation to ensure higher security access control
- Dual relays to control door lock and other security devices
- Keypad tamper lockout
- Adjustable relay output time from 1 to 99 seconds or latching (on/off)
- Mounts to recessed outlet box or can be surface mounted with optional back box
- Non-volatile memory protects programmed information in case of power loss

Specifications

Models	Voltage	Current	Users	PIN Code Digits	Inputs	Outputs	Keypad Housing
DG-101-BA DG-101-WI	12 to 24 VDC	40mA Pull-in, 10mA Holding at 12 or 24 VDC	49 +50	5	1 REX input 1 Door sensor input	2 Relays (NC/COM/NO) 0.4A/120VAC, 2A/30VDC	Plastic ABS

Dimensions

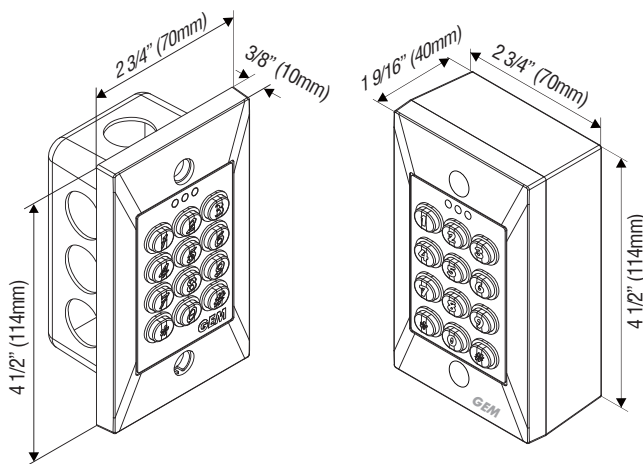

Warranty

The product is warranted against defects in material and workmanship while used in normal service for a period of 1 year from the date of sale to the original client. The GEM policy is one of continual development and improvement; therefore GEM reserves the right to change specifications without notice.

